

| ITEM NO. | PART NUMBER | DESCRIPTION | QTY. |
|----------|-------------|-------------|------|
| 1 | PSTD8-8 | NECK | 2 |
| 2 | BLDT2T-1 | BALL | 2 |
| 3 | NKSL-1.25 | NECK | 2 |
| 4 | TU34-5 | TUBE | 1 |

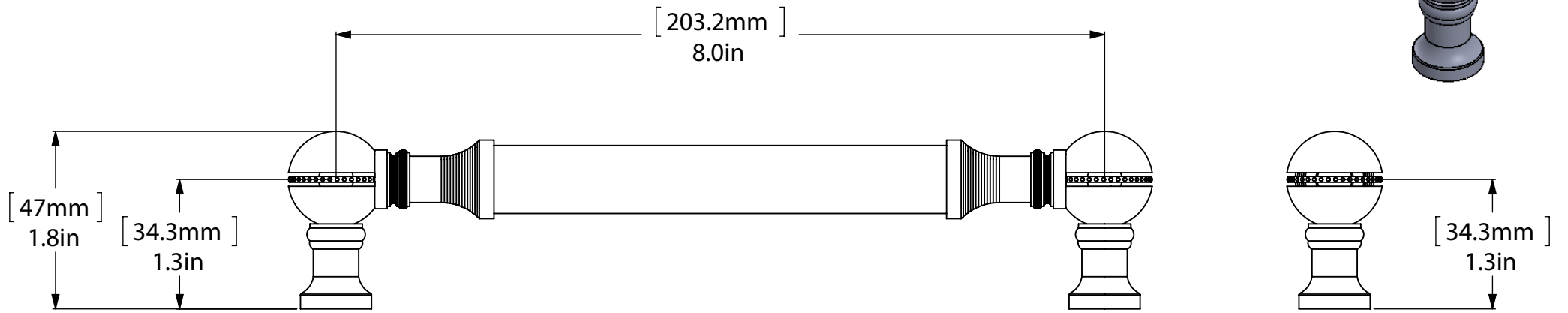

CONFIDENTIALITY/LIMITED LIABILITY STATEMENT
 This document (and any files attached to it) is confidential and intended only for the person or entity to which it is delivered. If you are not the intended recipient, then you have received this document by mistake and any use, dissemination, forwarding, printing or copying of this document and its file attachments is prohibited. Please notify ALLIED BRASS INC. immediately either by telephone or by email, delete the misdirected document from your system and destroy any copies you have made of it. We do not accept any liability for any loss or damage which may arise from your receipt of this document.

| UNLESS OTHERWISE STATED | | | INITIALS | DATE | ITEM | QTY | DRG/PART NO | CLIENT: | | | | |
|-------------------------|-------|----------|----------|-----------|--------------|-----|-------------|-------------|-------------|-------|-----------|----|
| DO NOT SCALE | X.XXX | +/-0.025 | DESIGNED | IJM | MATERIAL | | BRASS | WEIGHT | FINISH | TBD | | |
| DRAWING | X.XX | +/-0.1 | DRAWN | IJM | HEAT TREAT | | NA | | QUANTITY | | | |
| CHAMFER ALL | X.X | +/-0.25 | CHECKED | R. ANDRIS | CUSTOMER | | | CUSTOMER No | --- | | | |
| EDGES 0.5X45 | X | +/-0.75 | PROJ.ENG | | DESCRIPTION: | | | | DRAWING No. | REV | | |
| DRAWING ISO | | | SAFETY | | | | | | P-3-8 | 0 | | |
| | | | APPROVED | R. ANDRIS | | | | | SCALE | 1:1.5 | SHEET: 01 | A4 |
| | | | FILENAME | P-3-8 | | | | | | | | |

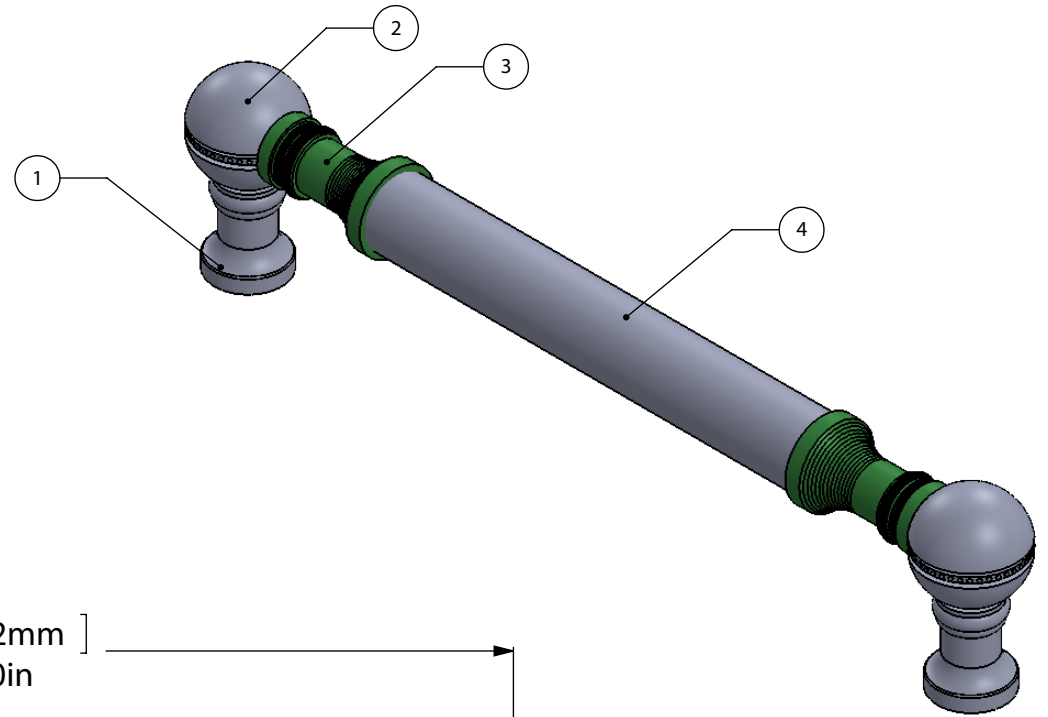